

SRL 6-40

Logic Unit SRL 6-40

Description

If the level electrode (high or low level limiter) is installed in an isolatable level pot outside the boiler, make sure that the level pot is drained and the connecting lines are rinsed at regular intervals.

For this purpose the connecting lines must be shut off and opened at regular intervals and by opening and closing the drain valve the lines and the level pot will be rinsed.

The logic unit SRL 6-40 is designed to be used in conjunction with control unit NRS 1-40.1 and NRS 1-40.2 to monitor the correct timing and sequence of valve operations.

The equipment consists of a touch screen with integral PLC and I/O system. Its design is in accordance with EN 50156 and the data exchange is effected via CAN bus using the CANopen protocol.

Function

The logic unit monitors the following times and process sequences:

- **Interval time:** This is the time interval at which, depending on the operating mode (24h / 72h operation), the connecting lines have to be purged.
- **Standby time:** The purging process must be initiated during this time. The standby period begins when the interval time has elapsed.
- **Purging time:** During this period the valves must be operated so as to initiate the purging process. Operation of the valves and exposure of the LW level electrode is sensed and signalled by the limit switches. If a message is not received during the purging time, the safety circuit will be interrupted. The monitoring of the purging time is a safety-relevant function because a water level limiter may be bypassed for a maximum of 5 minutes.

Every second the logic unit sends the following telegram: "Availability message SRL 6-40" to control unit NRS 1-40.1, NRS 1-40.2. The logic unit creates the time basis for the purging interval times and monitors the compliance of the purging intervals. After the interval time has elapsed the standby time is started and the interval time is reset to its initial value. During the standby time the purging process must be started.

If the standby time is exceeded, the logic unit sends the command "Open safety circuit" and "Evaluate limiter signal of LW level electrode 1 (2)" to the control unit. The start of the purging process is detected when one of the isolating valves is actuated.

At the beginning of the purging process the message "Ignore limiter signal of LW level electrode 1 (2)" and at the end of the process the message "Evaluate limiter signal of LW level electrode 1 (2)" is sent to the control unit.

If the purging time (5 min.) is exceeded, the logic unit sends the command "Open safety circuit" and "Evaluate limiter signal of LW level electrode 1 (2)" to the control unit. The command will only be cancelled when the purging process is successfully finished.

If an external high level alarm is monitored, the signals of the HW level electrode will not be evaluated.

Function – continued –

If a purging process is initiated outside the standby time, the interval time will be reset. The factory set interval time (24h or 72h) is stored on a CF card. This also applies to the standby and the purging time.

These settings are shown at the display of the logic unit.

The corresponding menu of the logic unit enables you to select the control unit with which the logic unit shall communicate and the level electrode to be monitored.

The factory-set code setting (NRS 1-40, NRS 1-41) or the configuration (NRS 1-40.1, NRS 1-40.2) when commissioning the control unit determines whether one or two logic units are to work with the control unit.

Technical data

Interface

Interface for CAN bus to ISO 11898, CANopen protocol

Supply voltage

24 VDC SELV (safety extra low voltage) + 20% / – 15 %

Inputs

1 four-channel digital input terminal DC 24 V
1 two-channel digital input terminal DC 24 V for 5 volt-free contacts of the limit switches mounted in valves

Outputs

1 two-channel digital relay output terminal AC 230 V, DC 30 V
2 make contacts, volt-free, max. contact rating AC/DC 2A for external indication "Stand-by time running" and "Stop"

Interval time

Factory-set default range: 2 to 336 hours

Standby time

Factory-set default range: 15 minutes to 2 hours

Purging time

Factory setting: 5 minutes

Indicators and adjustors

1 touch screen display

Power consumption

10 W

Protection

IP 65 to EN 60529

Admissible ambient temperature

0 – 50 °C

Enclosure

Field case for wall mounting
Case material: polycarbonate, colour: light gray

Cable entry / electrical connection

M 12 sensor connector (male), 5 poles, A coded
M 12 sensor connector (female), 5 poles, A coded
M 12 sensor connector (female), 8 poles, for connecting the limit switches

Weight

Approx. 2.1 kg

Logic Unit SRL 6-40

Important Notes

If both LW level electrodes are installed inside external level pots, one logic unit is required for each level pot. When ordering please state if the logic unit is required to work as equipment 1 or 2.

The enclosure of the logic unit is designed for wall mounting and should be installed close to the external level pot.

The limit switches of the isolating valves must be provided with volt-free relay contacts.

For connecting the limit switches we recommend a control cable, e.g. Ölflex 110 H, 7 x 1mm² and the installation of an intermediate distribution frame (IDF) close to the level pot. For connecting the IDF to the logic unit a control cable assembly (with connector) is supplied with the equipment.

If the logic unit SRL 6-40 is used, a separate stabilized safety power supply unit (e.g. SITOP Smart 24 V 2.5 A) must supply the CAN bus with 24 V DC.

The safety power supply unit must be electrically isolated from dangerous contact voltages and must meet at least the requirements on double or reinforced isolation acc. to DIN EN 50178 or DIN EN 61010-1 or DIN EN 60950 (safe electrical isolation). The power supply unit must be provided with an overcurrent protective device in accordance with EN 61010-1/VDE 0411.

In this case do not connect the CAN bus supply to the control units (terminals 1 and 5).

External signal LEDs indicating "Stand-by time" and "Stop" can be directly connected to the relay output terminals. Use the cable gland in the enclosure for the connecting cables.

Order & Enquiry Specification

GESTRA Logic Unit type SRL 6-40,
Equipment number
Interval timeh
Stand-by time.....min

Ancillaries

- Level electrodes NRG 1x-40, NRG 1x-41, NRG 1x-41.1
- Control units NRS 1-40.1, NRS 1-40.2
- Level pot MF xxx for level electrodes
- 2 Shut-off valves GAV xxx-II
- 1 Drain valve GAV xxx-II

LV (Low Voltage) Directive and EMC (electromagnetic compatibility)

The equipment meets the requirements of the Low Voltage Directive 2014/35/EU and the EMC Directive 2014/30/EU.

ATEX (Atmosphère Explosible)

According to the European Directive 2014/34/EU the equipment must not be used in potentially explosive areas.

Supply in accordance with our general terms of business.

Dimensions

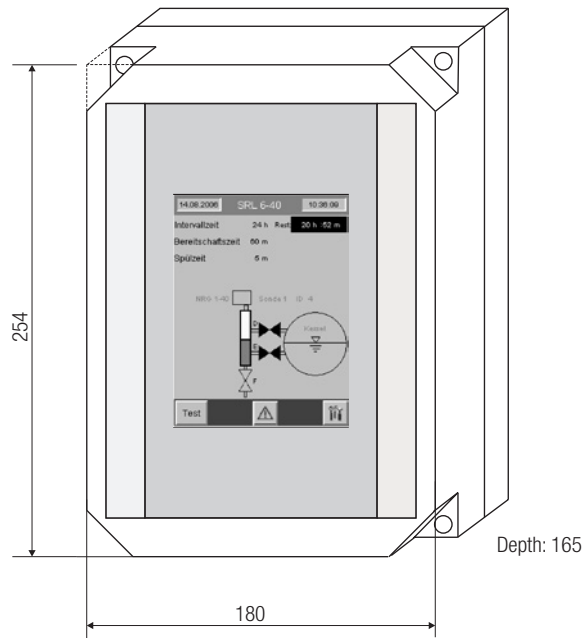

Electrical Connection

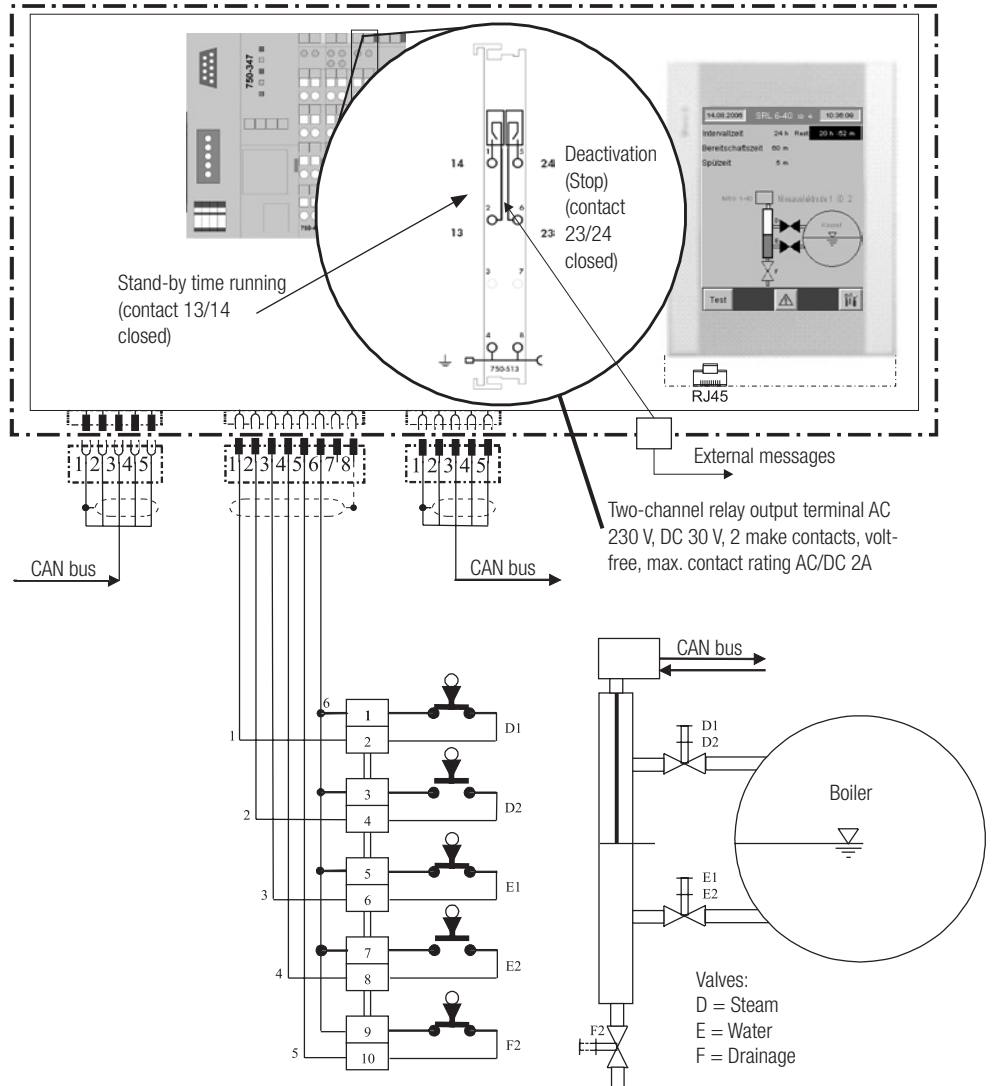

Drawn position of valve limit switches: Valves in normal operating position.

GESTRA AG

Münchener Straße 77, 28215 Bremen, Germany
Telefon +49 421 3503-0, Telefax +49 421 3503-393
E-mail info@de.gestra.com, Web www.gestra.de

